

MP LINE

Raccordi Automatici per Lubrificazione, 80 bar
Medium Pressure Push-in Fittings, 80 bar
Raccords Instantanés pour le graissage, 80 bar
Mitteldrucksteckverschraubungen, 80 bar



MP è un raccordo automatico concepito per impieghi fino a 80 bar nel campo della lubrificazione centralizzata.

Con il suo contenuto tecnico, la serie MP completa la gamma già esistente di raccordi per la lubrificazione ed offre continuità alle caratteristiche distintive dell'intera produzione C.MATIC: rapidità di connessione, garanzia di prestazione ed affidabilità.

MP is a push-in fitting conceived for Medium pressure grease applications up to max 80 bar.

MP completes, with its technical features the existing products offer for central lubrication applications and highlights further the distinguishing marks of the whole C.MATIC production: Quick connections, performance and reliance guarantee.

MP est un raccord instantané conçu pour garantir la connection jusqu'à 80 bar dans le domaine du graissage centralisé.

Cette série complète avec ses caractéristiques techniques la gamme de lubrification centralisée tout en gardant les signes distinctifs de la production C.MATIC: rapidité de connection, garantie de performance et de fiabilité.

MP ist eine Steckverschraubung, geeignet für Mitteldruck bis 80 bar im Bereich Zentralschmierung.

MP (als zusätzliche Variante) ergänzt mit ihren technischen Eigenschaften die schon bestehende Verschraubungspalette für Zentralschmierung und setzt die Unterscheidungsmerkmale der C.MATIC Herstellung fort und zwar schnelle Verbindungsfähigkeit, Leistung und Zuverlässigkeit.

1	2	3	4
Corpo Body Corps Körper	Viti filettate Threaded Screws Filets Gewinde	Pinza aggraffaggio Gripping collet Pince Spannzange	Guarnizioni Seals Joint d'étanchéité Dichtung
Ottone UNI EN 12164 CW614N - UNI EN 12165 CW617N Nichelato Brass UNI EN 12164 CW614N - UNI EN 12165 CW617N Nickel Plated Laiton UNI EN 12164 CW614N - UNI EN 12165 CW617N Nickelé Messing UNI EN 12164 CW614N - UNI EN 12165 CW617N vernickelt	Ottone UNI EN 12164 CW614N Nichelato Brass UNI EN 12164 CW614N Nickel Plated Laiton UNI EN 12164 CW614N Nickelé Messing UNI EN 12164 CW614N vernickelt	Ottone UNI EN 12164 CW614N Brass UNI EN 12164 CW614N Laiton UNI EN 12164 CW614N Messing UNI EN 12164 CW 614N	NBR NBR NBR NBR



-20°C ÷ 70°C



Max 80 bar

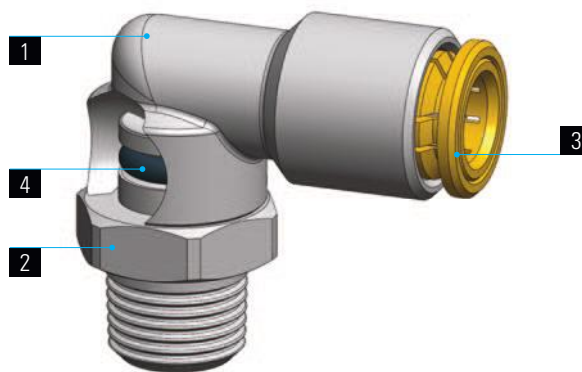

	M6x1	M8x1	M10x1	R1/8	R1/4
4	•	•	•	•	
6	•	•	•	•	
8			•	•	•

SPECIFICHE TECNICHE

Tubi di collegamento consigliati:
PA6-6 (4x1,5 – 6x3), PA12 HR
Tolleranze accettabili sui tubi:
+/- 0,07 mm fino a Ø 6 mm.

Campi di applicazione:
Impianti di lubrificazione.



Il valore di massima pressione d'esercizio è influenzato dal tipo di tubo impiegato e dalla temperatura che può ridurre sensibilmente la pressione di scoppio del tubo.

DATA SHEET

Recommended tubings:
PA6-6 (4x1,5 – 6x3), PA12 HR
Acceptable Tolerances on the tubings:
+/- 0,07 mm up to Ø 6 mm.

Application fields:
Lubrication installations.



The max pressure rate achievable can vary depending on the tubing used and on the room temperature. These two factors may in fact lower the tube bursting pressure.

REINSEIGNEMENTS TECHNIQUES

Tubes conseillés:
PA6-6 (4x1,5 – 6x3), PA12 HR
Tolerances sur les tubes:
+/- 0,07 mm jusqu'au Ø 6

Domaines d'application:
système de graissage.



La valeur max. de la pression est en fonction du tube employé et de la température d'ambiance, éléments qui peuvent baisser la pression d'éclatement du tube.

TECHNISCHE AUSKÜNFTE

Empfohlene Schläuche:
PA6-6 (4x1,5 – 6x3), PA12 HR
Schlauchtoleranzen:
+/- 0,07 mm bis Ø 6 mm.

Anwendungsbereiche:
Schmieranlagen



Der Druckbereich wird stark von den eingesetzten Schläuchen und Aussentemperaturen beeinflusst, die den Berstdruck des Schlauches reduzieren können.

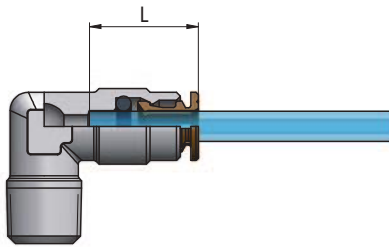

Øe Tubo	L
4	14,5
6	17

ISTRUZIONI DI MONTAGGIO

ASSEMBLY INSTRUCTIONS

INSTRUCTIONS DE MONTAGE

MONTAGEANWEISUNGEN

1. Tagliare il tubo a 90° (servendosi della pinza tagliatubo RA 34) verificando l'assenza di bave interne ed esterne e facendo attenzione che il tubo non si presenti ovalizzato dopo il taglio.
2. Inserire il tubo nel raccordo spingendolo fino in battuta.

1. Cut the tube square (by means of a hose cutter i.e. our RA 34) making sure that no burrs are left and that the tube is not oval.
2. Insert the tube into the fitting until it bottoms.

1. Sectionner le tube à 90° par notre coupe tube RA 34 en prenant soin de ne pas créer des bavures et de ne pas ovaliser le tube.
2. Pousser le tube jusqu'au fond du raccord.

1. Schlauch mittels unserer Schlauchschere (RA 34) 90° abschneiden und entgraten.
2. Darauf achten, daß der Schlauch danach nicht oval gequetscht ist und dann ihn bis zum Verschraubungsanschlag einstecken.

Estrazione del tubo

Esercitare una leggera pressione sull'anello estrattore, estraendo contemporaneamente il tubo dal corpo del raccordo.

Tube release

While pressing on the release ring, pull out the tube from the fitting.

Débranchement du tube

Appuyer sur le poussoir en métal et tirer simultanément sur le tube.

Schlauchlösen

Auf den Druckring drücken und gleichzeitig den Schlauch rausziehen.

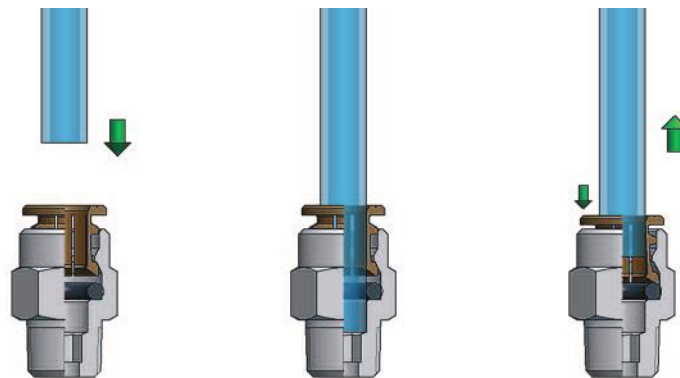

Effettuato il collegamento, assicurarsi che il tubo inserito nel raccordo non sia sottoposto ad alcuna forza di trazione; è necessario inoltre rispettare durante il collegamento del tubo il raggio minimo di curvatura consigliato così come riportato nella sezione tubi di questo catalogo tecnico (vedi pag. 312)

Al fine di evitare lo sgancio involontario del tubo nessun oggetto deve venire a contatto con l'anello estrattore del raccordo evitando così l'esercizio di qualsiasi forza indesiderata, anche solo laterale, che potrebbe causare la pressione dell'anello estrattore e conseguente rilascio del tubo.

Per il serraggio delle parti filettate del raccordo si raccomanda di attenersi alle coppie consigliate riportate a pag.6



Once the tubing is connected to the fitting, make sure that the tubing is not subject to any tensile strength and that the min. recommended bending radius stated in the tubing section of this catalogue is complied with (see page 312).

To prevent any accidental tube release, no components have to come in touch with the release ring and exercise any unwanted pressure on the same. Indeed however lateral, any load on the release ring may cause the tube disconnection.

To tighten threads, please check out our tightening torque chart illustrated at page 6.



Une fois effectué le branchement, s'assurer que le tube inséré dans le raccord n'est soumis à aucune force de traction. Egalement, il est nécessaire de respecter, lors du branchement du tube, le rayon minimum de courbure conseillé dans la section tubes de ce catalogue technique (voir la page 312).

Afin d'éviter le décrochage involontaire du tube, aucun objet ne doit entrer en contact avec la bague d'extraction du raccord, empêchant ainsi l'exercice de toute force indésirable, ne serait-ce que latérale, qui pourrait provoquer la pression de la bague d'extraction et donc le relâchement du tube.

Pour le serrage des parties filettées du raccord, il est recommandé de s'en tenir aux couples de serrage conseillés et reportés à la page 6.



Nach der Schlauchverbindung, sicherstellen, dass der in die Verschraubung eingeführte Schlauch keinen Zugbelastungen ausgesetzt ist; beim Anschluss des Schlauchs muss der empfohlene Mindestbiegeradius eingehalten werden, gemäß den in diesem technischen Katalog im Schlauchabschnitt, angegebenen Hinweisen (siehe Seite 312).

Um das versehentliche Lösen des Schlauchs zu verhindern, darf kein Gegenstand den Lösering der Verschraubung berühren. Keine unerwünschte Kraft darf auch nicht seitlich einwirken und kein Druck soll auf den Lösering ausgeübt werden, denn dies das Schlauchlösen verursachen könnte.

Zum Festziehen der Gewinde sich an den, auf Seite 6, empfohlenen Drehmomente einhalten.

MP 11

Diritto maschio conico

Taper Straight, male

Union simple mâle conique

Gerade Einschraubverschraubung, kegelig

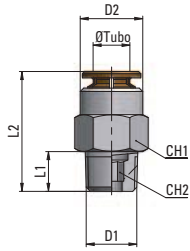

Tipo	Øe Tubo	D1	D2	L1	L2	CH1	CH2	g Δ
11 04 18	4	R1/8	9	7,5	18,5	10	3	7,2
11 04 M6x1	4	M6x1	9	8	23	10	2,5	7,6
11 04 M8x1	4	M8x1	9	8	20	10	3	6,7
11 04 M10x1	4	M10x1	9	8	20	11	3	9,3
11 06 18	6	R1/8	12	7,5	21,5	12	3	10,3
11 06 M6x1	6	M6x1	12	8	25,5	12	2,5	11,6
11 06 M8x1	6	M8x1	12	8	25,5	12	4	12,3
11 06 M10x1	6	M10x1	12	8	22	12	4	10,9
11 08 18	8	R1/8	14	7,5	25,5	14	5	-
11 08 14	8	R1/4	14	11	25,5	14	6	-
11 08 M10x1	8	M10x1	14	8	26	14	5	-

MP 14

Gomito maschio conico

Taper Elbow Fitting, male

Raccord à coude mâle conique

Winkelverschraubung, kegelig

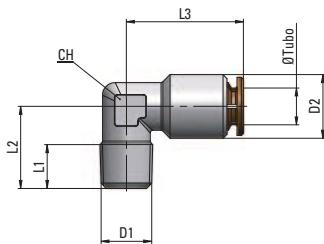

Tipo	Øe Tubo	D1	D2	L1	L2	L3	CH	g Δ
14 04 18	4	R1/8	9	7,5	15,5	20	10	12,6
14 04 M6x1	4	M6x1	9	8	17	20	10	13,3
14 04 M8x1	4	M8x1	9	8	17	20	10	13,4
14 04 M10x1	4	M10x1	9	8	18	20	10	14,3
14 06 18	6	R1/8	12	7,5	15,5	21	10	14,2
14 06 M6x1	6	M6x1	12	8	17	21	10	14,6
14 06 M8x1	6	M8x1	12	8	17	21	10	14,8
14 06 M10x1	6	M10x1	12	8	18	21	10	15,8
14 08 18	8	R1/8	14	7,5	19	23,5	12	-
14 08 14	8	R1/4	14	11	20	23,5	12	-
14 08 M10x1	8	M10x1	14	8	19	23,5	12	-

MP 15

Gomito maschio conico girevole

Taper Swivelling Elbow Fitting, male

Raccord à coude tournant, mâle conique

Schwenkbare Winkelverschraubung, kegelig

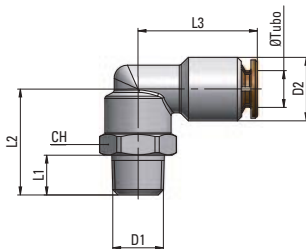

Tipo	Øe Tubo	D1	D2	L1	L2	L3	CH	g Δ
15 04 18	4	R1/8	9	7,5	20	20	13	21,9
15 04 M6x1	4	M6x1	9	8	20,5	20	13	19,9
15 04 M8x1	4	M8x1	9	8	20,5	20	13	20,7
15 04 M10x1	4	M10x1	9	8	21,5	20	13	23,4
15 06 18	6	R1/8	12	7,5	20	21,5	13	24,2
15 06 M6x1	6	M6x1	12	8	20,5	21,5	13	21,7
15 06 M8x1	6	M8x1	12	8	20,5	21,5	13	22,6
15 06 M10x1	6	M10x1	12	8	21,5	21,5	13	25,8
15 08 18	8	R1/8	14	7,5	20,5	23	13	-
15 08 14	8	R1/4	14	11	24	23	13	-
15 08 M10x1	8	M10x1	14	8	22	23	13	-

MP 26

Giunzione Intermedia

Union

Union simple égale

Gerade Verbindung

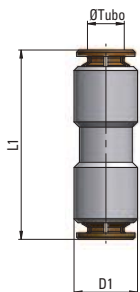

Tipo	Øe Tubo	D1	L1	g Δ
26 04 04	4	9	30	10,7
26 06 06	6	12	33,5	15,7
26 08 08	8	14	36	-

MP 28

Gomito Intermedio

Union Elbow

Raccord à Coude

Winkelverschraubung

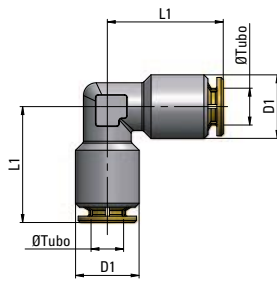

Tipo	Øe Tubo	D1	L1	g 
28 04 04	4	9	20,5	-
28 06 06	6	12	22	-
28 08 08	8	14	23,5	-

MP 29

T Intermedio

Union Tee

T égal

T-Verschraubung

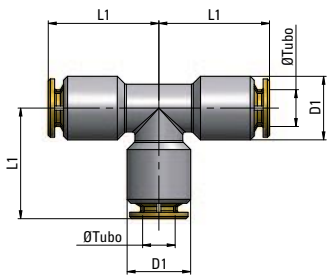

Tipo	Øe Tubo	D1	L1	g 
29 04 04	4	9	20	-
29 06 06	6	12	21	-
29 08 08	8	14	22	-